

TOWN OF NEW GLARUS
PARK COMMISSION MEETING
18 September 2024, 6:00 PM
AGENDA

NOTICE IS HEREBY GIVEN that the Town of New Glarus Park Commission, County of Green, will conduct a meeting for the transaction of business as is by law required permitted at such meeting as follows:

LOCATION: New Glarus Town Hall
26 5th Avenue
New Glarus, WI 53574

Zoom Link: <https://us06web.zoom.us/j/85472471153?pwd=16t6gFnXu3j8oPllG7WEjOcv7DrpNa.1>

Meeting ID: 854 7247 1153

Passcode: 414290

Dial by your location: 312 626 6799

1. Call to Order
2. Proof of Posting
3. Approve Minutes from Regular Meeting on August 21, 2024
4. Public Comments
5. Update on Prairie Restoration at Town Park – Jason & Kelly
6. Review Additional Prairie Seed Options—Frank Grenzow
7. Update on Mowing at Town Park by Frank Grenzow
8. Update on Trail Progress and Public Facility Siting Within Town Park – Chris
9. Discuss and Consider Invasives Removal and Seeding at Bluebird Ridge—Report from Jason on His Meeting at BBRC with Steve Fabos of Indigenous Restorations
10. Discuss and Possibly Approve the Use of Profits from the Annual Tree Sale
11. Updated 2024 Budget to Actual and Attendance
12. Discussion with Possible Action to Authorize the Transfer of Certificate of Deposit at Maturity to Park Sinking Fund Account on or After November 19, 2024
13. Update on Southwest Badger Natural Resource Conservation Fund Grant Application due Sept. 15, 2024 – Harry & Kelly
14. Discuss and Consider Possible Revisions to Ordinance 2023-01 Codifying the Town of New Glarus Park Commission – Mark
15. Schedule Next Meeting, October 16, 2024, at 6:00 PM
16. Adjourn

Posted: 9.12.2024

New Glarus Town Hall
New Glarus Garage
New Glarus Post Office

<https://townofnewglarus.com/>

Harry Pulliam, Chair
New Glarus Park Commission
John Wright, Clerk-Treasurer

Pursuant to applicable law, notice is hereby given that a quorum or a majority of the New Glarus Town Board or Plan Commission Members may attend this meeting. Information presented at this meeting may help form the rationale behind future actions that may be taken by the Town of New Glarus Board. Persons requiring additional services to participate in a public meeting may contact the Town Clerk for assistance at 527-2390.

TOWN OF NEW GLARUS
PARK COMMISSION MEETING
August 21, 2024
Minutes

Attending: Harry Pulliam (Chair), Kelly Ruschman, Mark Pernitz, Chris Narveson, Jason Neton, and Mona Sue French.

Absent: Rose Pertzborn

Also attending: Nancy Streiff: Deputy-Treasurer and Frank Grenzow: Town of New Glarus resident.

1. **Call to Order** – Chair Pulliam called the meeting to order at 6:05 PM.
2. **Proof of Posting** – Deputy Clerk Treasurer Streiff attested to proper proof of posting.
3. **Approve Minutes** – A motion to approve the July 17, 2024. Regular minutes as presented, was made by French; seconded by Ruschman. Motion carried, 6-0.
4. **Public Comments** – The members in attendance discussed whether hunting would be allowed at the Town of New Glarus Park this year. French made a motion that the Town of New Glarus will not allow any hunting on the park property. Ruschman seconded the motion. Motion carried, 6-0.

The Town of New Glarus has been helping the Village of New Glarus with site preparations for the updated Candy Cane Park. On Saturday, August 24th at 8 AM there will be a workday to start assembling the new accessible playground equipment. Narveson noted that Town Patrolman, Ron Roesslein has donated a considerable amount of personal time working on this effort.

5. **Note That Mark Pernitz has Agreed to Serve Another 7-Year Term on the Park Commission**

6. **Update on Prairie Restoration at Town Park** – Jason & Kelly

Neton reported that he had meetings with four vendors regarding work to restore the prairie at the Town Park including Heartland Ecological Group, Resource Environmental Solutions, Adaptive Restoration, and Quercus Land Stewardship Services.

Neton stated that he gathered feedback from each vendor on their recommendations and is expecting to receive quotes in a couple of weeks. The members of the Park Commission will review the quotes and determine the next steps at the September meeting. This effort will be the first step of a larger project. The Town may hire different groups to complete various tasks.

According to Neton, vendors suggested working on the eight to nine acres that are around the remnant prairie and then to use a combination of drill seeding and broadcast seeding depending on the location.

Per Grenzow, one advantage to drill seeding on hillsides would be that the seed would be less likely to wash away. Most of the vendors are willing to make custom seed mixes. Cost for seed mixes can range from \$300 - \$500 per acre, up to as much as \$3,000 per acre. One option would be to select a basic mix at \$300/acre range and then supplement with seeds from the Prairie Enthusiasts. Another option could be to work with Steve Fabos, who the Parks Commission has been working with in the past. Prior to planting the seeds, herbicide will likely need to be applied.

Grenzow recommended that it would be best to remove trees and brush when fields are bare before planting prairie seeds. Grenzow offered to cut down some trees that should be removed. Narveson offered to talk to Ron Roesslein about this and get back to Grenzow.

As a group, the Park Commission and any willing volunteers may start working on the Oak knoll.

7. **Update on Mowing at Town Park** – Frank Grenzow

Grenzow mowed a 12-foot-wide path around the Town Park. There are several trees and bushes along the fence that could be removed to increase the amount of usable land in the park. If these are removed, then the trail around the park could be closer to the outer perimeter providing a buffer for invasives from neighboring properties as well as provide a fire break. Per Grenzow, all four prairie restoration companies suggested that we plant the prairies out to the edges and then mow the trails where we want them.

8. **Report on Sunny Peace Prairie in Orfordville** – Frank Grenzow

Sunny Peace Prairie is similar in size to the New Glarus Town Park property. Grenzow recommends that all Park Commission members watch the 2-minute videos linked in the email provided in the packet. The videos explain the process to restore land to a native prairie, a cycle which usually takes four years.

9. **Update on Decision by DNR re: Grant for Trail Within Town Park** – Chris
Per Narveson, the New Glarus Town Board has approved hiring up to two people to work on the trails. They will ensure the grade/pitch are correct and that the storm water is controlled. The goal will be to try to work with the lay of the land rather than put in culverts. The DNR has given the Town a deadline of June 2025 to finalize trail construction. The goal is to have as much work completed this fall if as is possible.
10. **Discuss and Consider Invasives Removal and Seeding at Bluebird Ridge** – Report from Jason on his Meeting at BBRC with Steve Fabos of Indigenous Restorations. No update – defer to September agenda.
11. **Annual Tree Sale Income and Expenses Report** - The report was shared with the members present.
12. **Updated 2024 Budget to Actual** - The report was shared with those present.
13. **Update on Southwest Badger Natural Resource Conservation Fund Grant Application due Sept. 15, 2024** – Harry & Kelly. This is under review by Ruschman, Pertzborn, and Wright. Neton made a motion to submit the Grant Application and Narveson seconded. Motion approved 6 – 0.
14. **Discuss and Consider Possible Revisions to Ordinance 2023-01 Codifying the Town of New Glarus Park Commission** – Mark. No update
15. **Schedule Next Meeting**, September 18, 2024, at 6:00 PM
16. **Adjourn** – Motion to adjourn by Pernitz; seconded by Ruschman. Meeting adjourned at 7:48 PM.

Approved:

Prepared by Nancy Streiff, Deputy Treasurer

Clerk Treasurer

From: Harry Pulliam <hfpulliam@gmail.com>
Sent: Thursday, September 12, 2024 12:53 PM
To: Clerk Treasurer
Cc: Deputy Clerk; Deputy Treasurer
Subject: Fwd: Free Prairie Seed

John,

Below is an email that I received this morning from Frank Grenzow. I've added a discussion of it to the agenda for next week's Park Commission meeting. Please add a copy of it to the packet.

Thanks,

Harry

--

Harry Pulliam

(608) 228-5439

"It ain't what you don't know that gets you into trouble. It's what you know for sure that just ain't so."

-Mark Twain

----- Forwarded message -----

From: deerhollow@tds.net <deerhollow@tds.net>
Date: Thu, Sep 12, 2024 at 12:51 AM
Subject: Free Prairie Seed
To: Jason Neton <jasonneton@gmail.com>, Kelly Ruschman <Kelly010856@gmail.com>
Cc: Chris Narveson <cnarveson@townofnewglaruswi.gov>, Harry Pulliam <hfpulliam@gmail.com>

All,

I've mentioned this to Jason and Kelly. This non-governmental organization may supply a prairie seed mix, free of cost, along with 5 year technical follow-up:

<https://www.beeandbutterflyfund.org/>

The program is open to governmental entities, and is free for 2 to 25 acre properties, per year. Here is link

to the Habitat Guide which gives the details of the program including site prep requirements:

<https://www.beeandbutterflyfund.org/uploads/1/3/3/3/133320811/habitatguide23v8.pdf>

Note that on page 11 of the Habitat Guide they discuss Native vs. Naturalized Species.

Link to draft of the Interest Form, which is required to get the process rolling:

https://wkf.ms/48pmCl3?draft_submission=230776bc-2f13-410c-b034-3f3c6429ec8d

If there is a preference to have a Parks Commissioner submit the Interest Form, here is link to blank form:

<https://forms.monday.com/forms/038e1e680e34c44a3f34f7ca32a03f05?r=use1>

Frank Grenzow

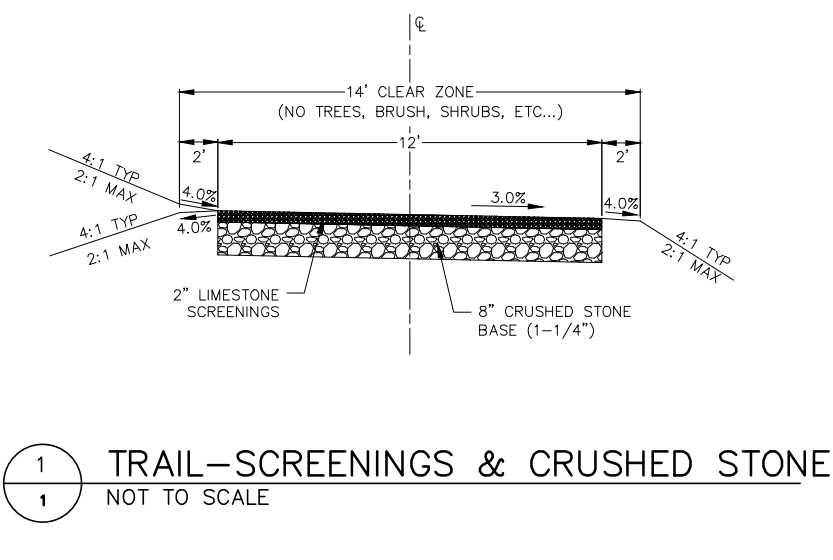
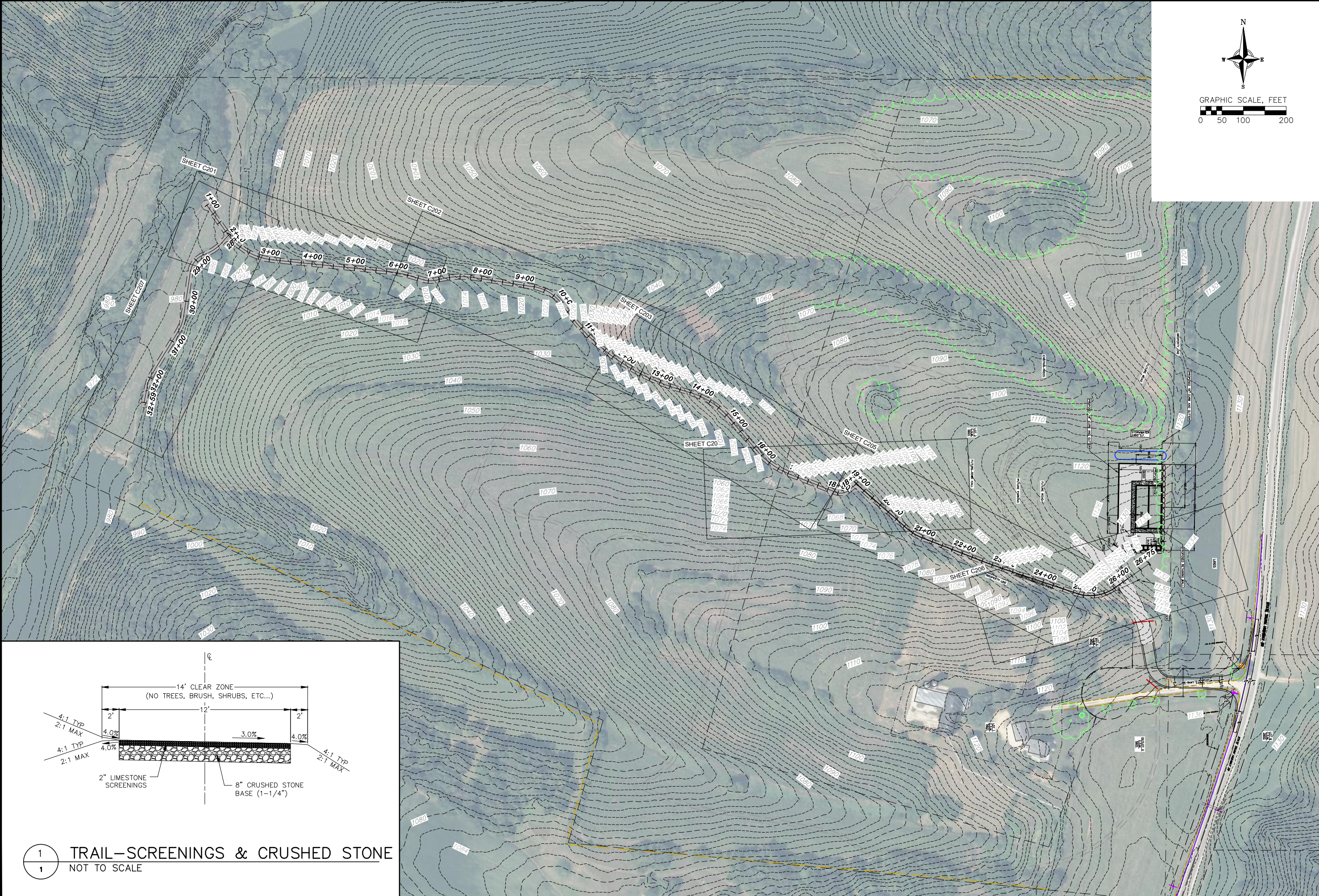
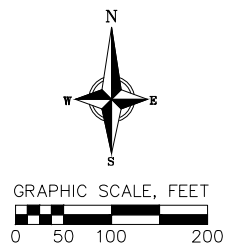

1 TRAIL-SCREENINGS & CRUSHED STONE
1 NOT TO SCALE

PROJECT OVERVIEW
Community Park Trail
TOWN OF NEW GLARUS
GREEN COUNTY, WISCONSIN

REVISIONS		REVISIONS	
NO.	DATE	NO.	DATE

DATE: 09/05/2024
DRAFTER: DPER
CHECKED: TSCH
PROJECT NO.: 230307

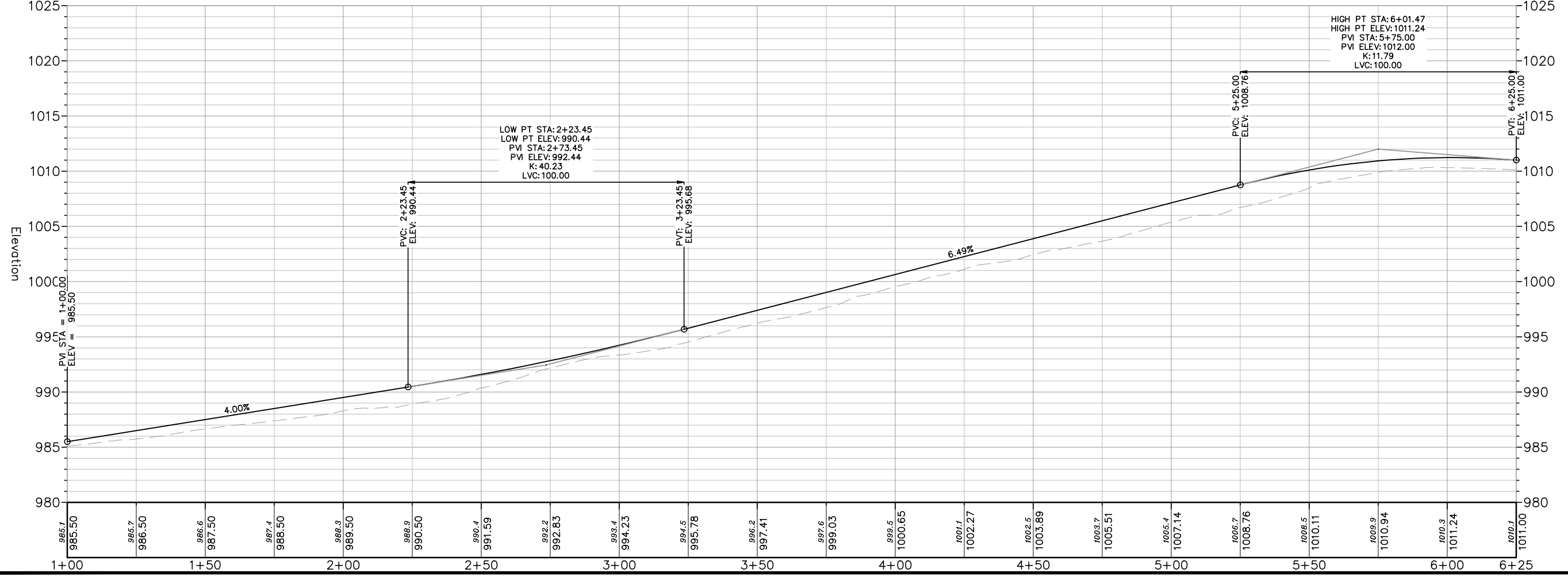
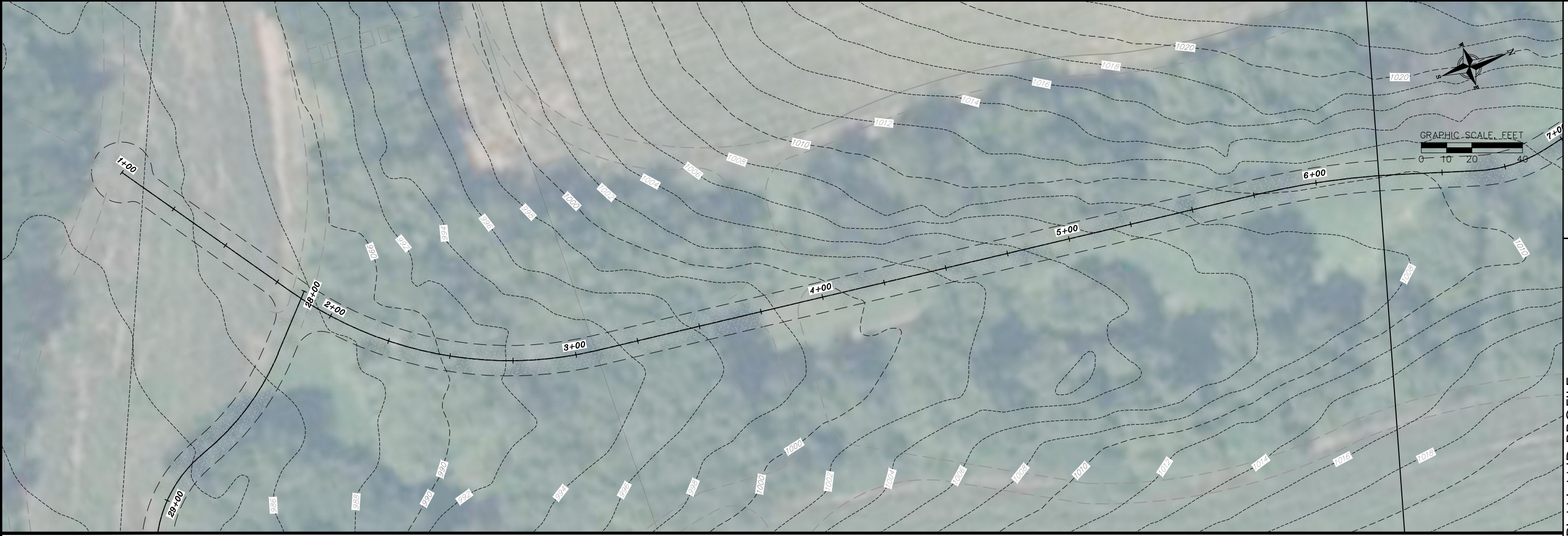

TRAIL SECTION 1 - PLAN AND PROFILE

Community Park Trail
TOWN OF NEW GLARUS
GREEN COUNTY, WISCONSIN

REVISIONS		REVISIONS	
NO.	DATE	NO.	DATE

DATE: 09/05/2024
DRAFTER: DPER
CHECKED: TSCH
PROJECT NO.: 230307

C201

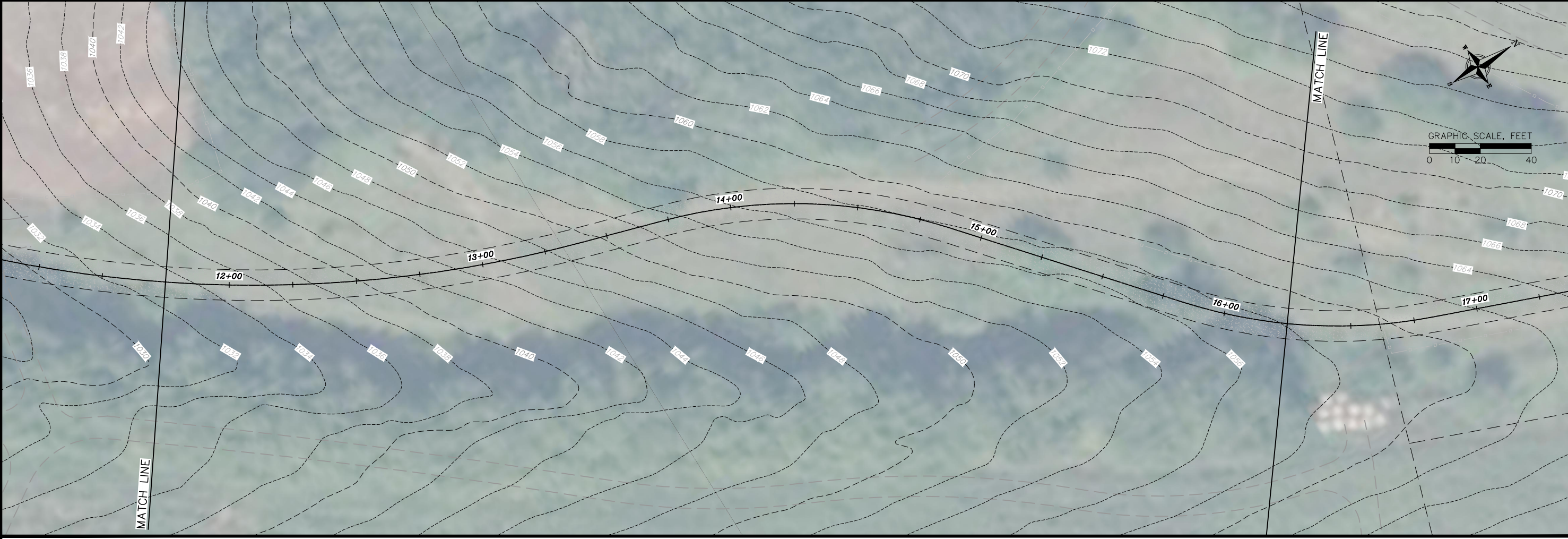

TRAIL SECTION 1 - PLAN AND PROFILE
 Community Park Trail
 TOWN OF NEW GLARUS
 GREEN COUNTY, WISCONSIN

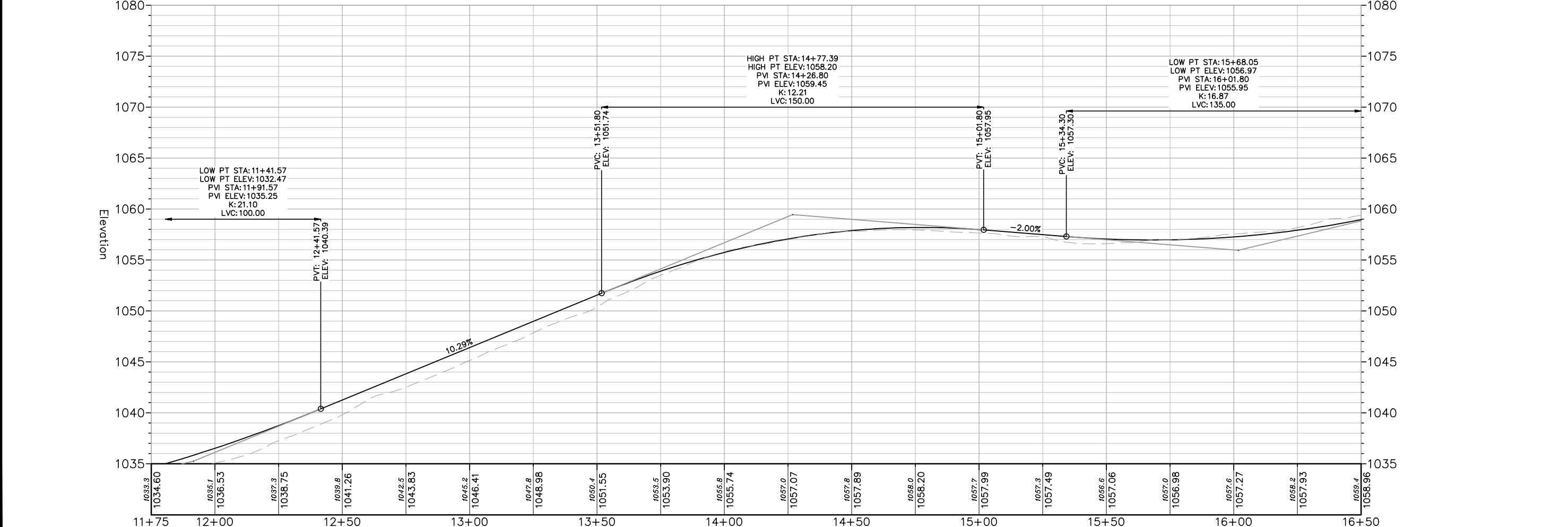

REVISIONS		REVISIONS	
NO.	DATE	NO.	DATE

DATE	09/05/2024
DRAFTER	DPER
CHECKED	TSCH
PROJECT NO.	230307

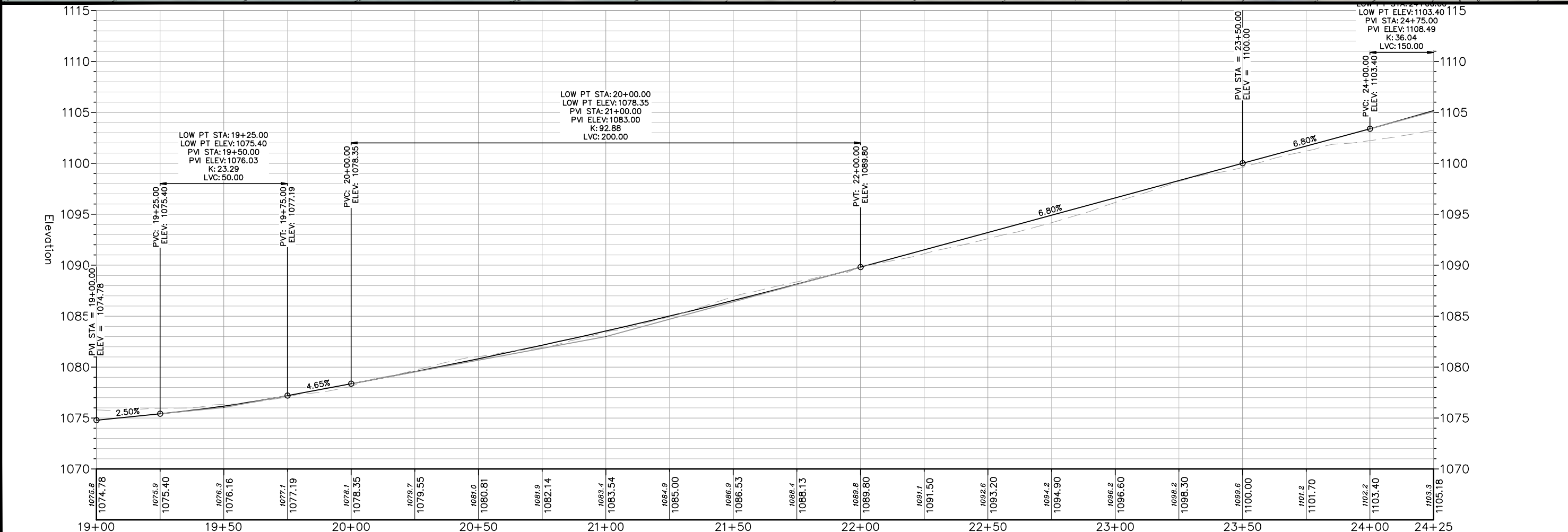
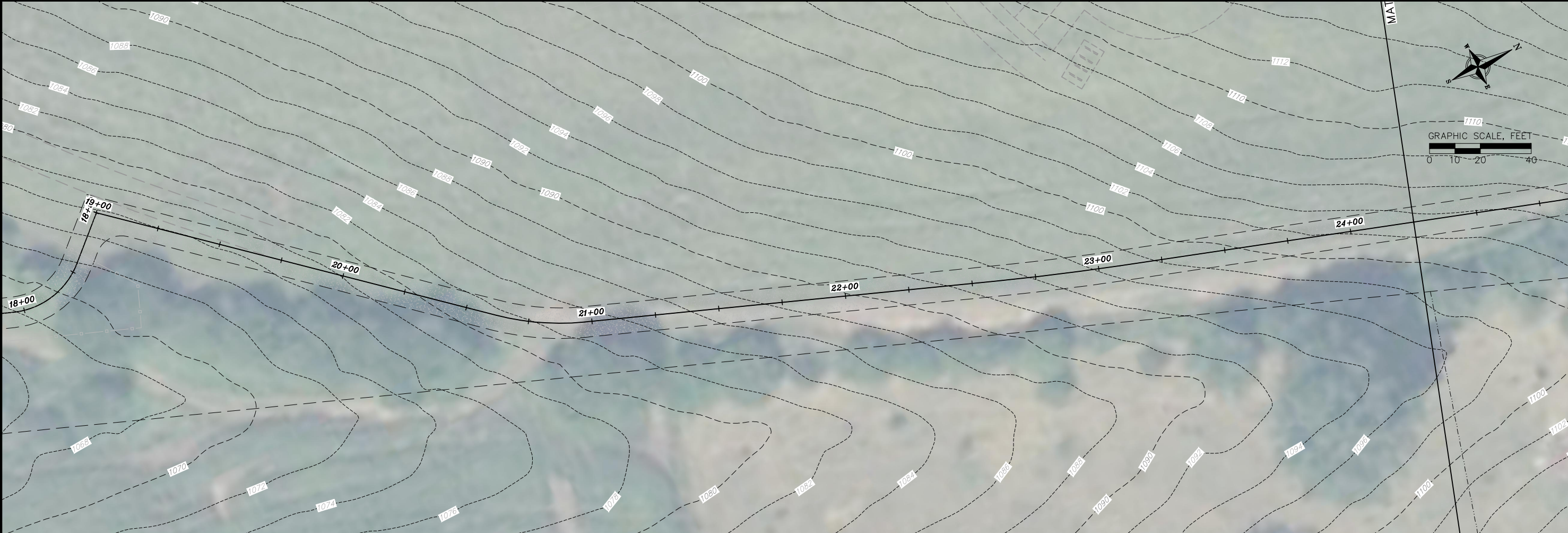

TRAIL SECTION 2 - PLAN AND PROFILE
Community Park Trail
TOWN OF NEW GLARUS
GREEN COUNTY, WISCONSIN

REVISIONS		REVISIONS	
NO.	DATE	NO.	DATE

DATE: 09/05/2024
 DRAFTER: DPER
 CHECKED: TSCH
 PROJECT NO.: 230307

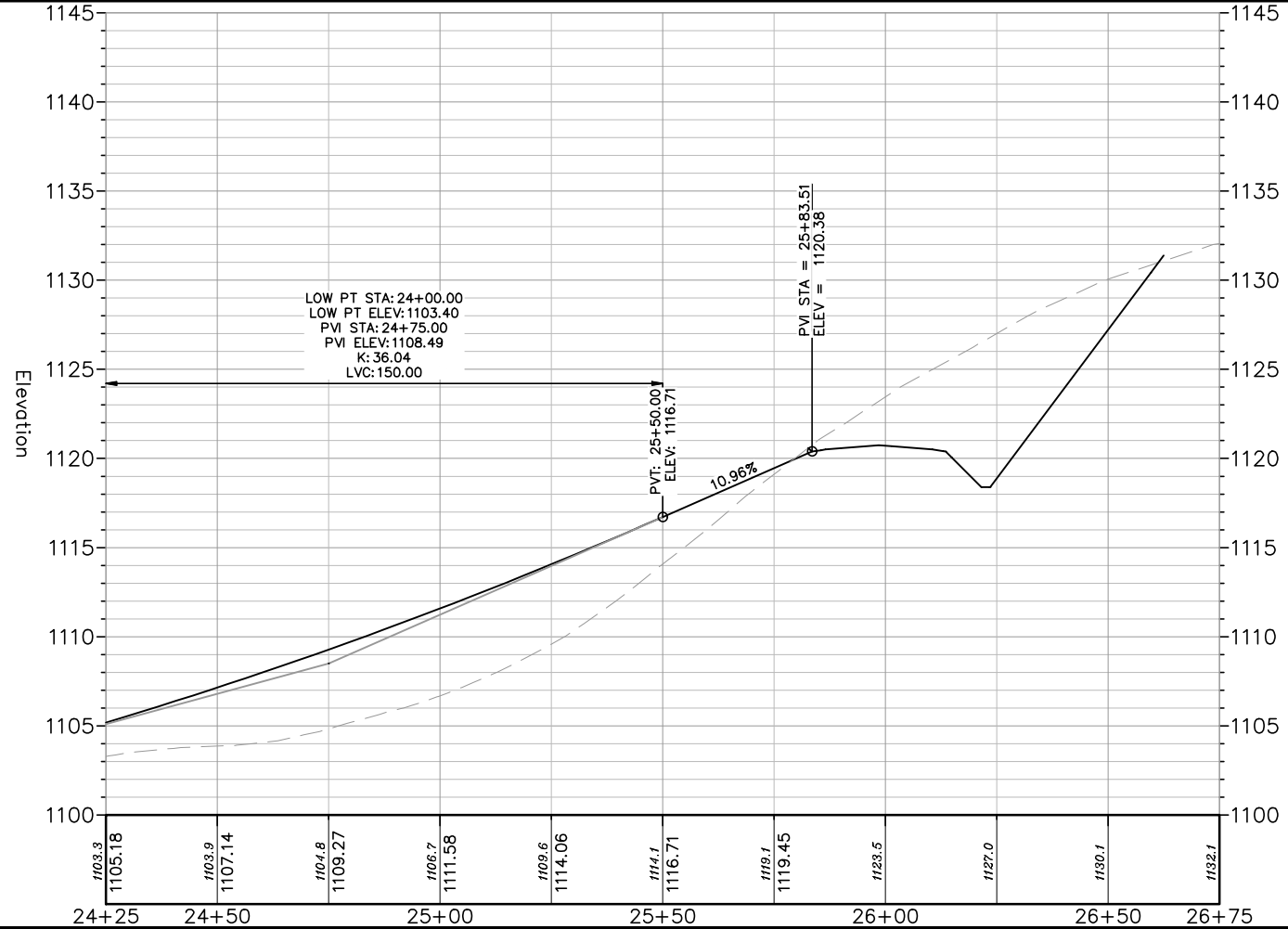
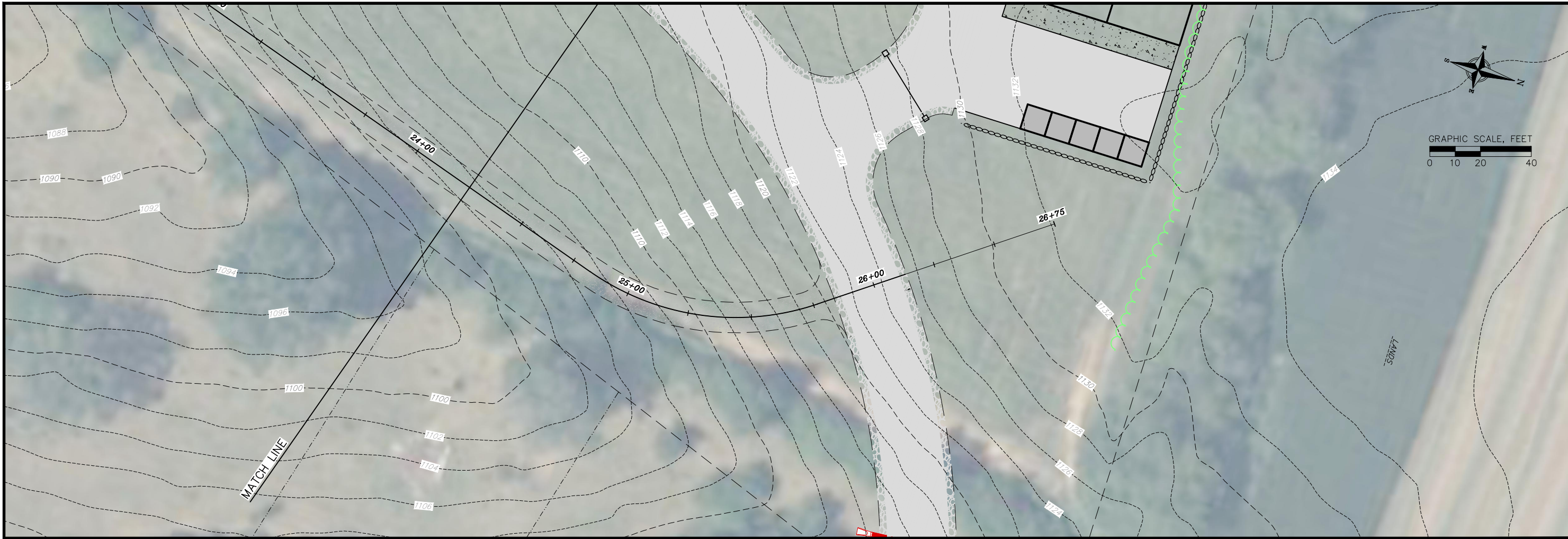

TRAIL SECTION 2 - PLAN AND PROFILE

Community Park Trail
TOWN OF NEW GLARUS
GREEN COUNTY, WISCONSIN

REVISIONS		REVISIONS	
NO.	DATE	NO.	DATE

DATE: 09/05/2024
DRAFTER: DPER
CHECKED: TSCH
PROJECT NO.: 230307

C206

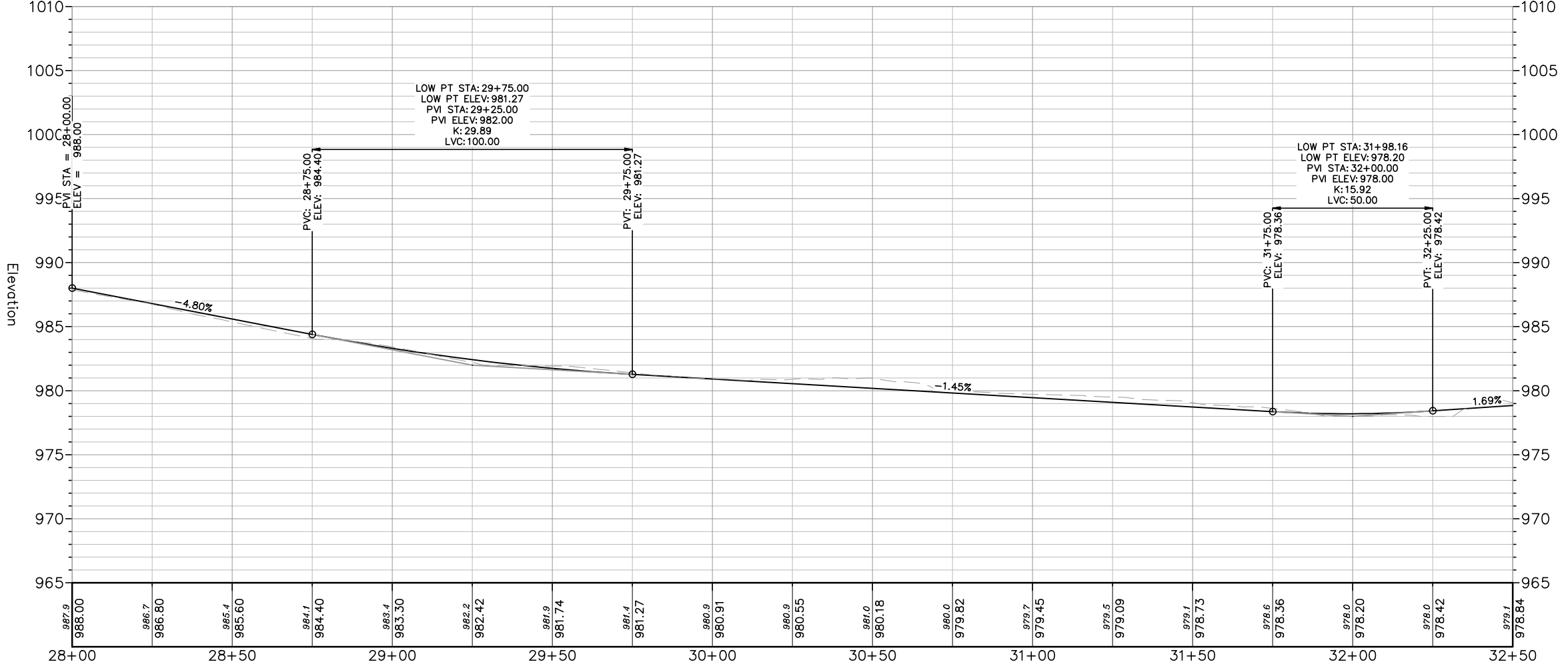
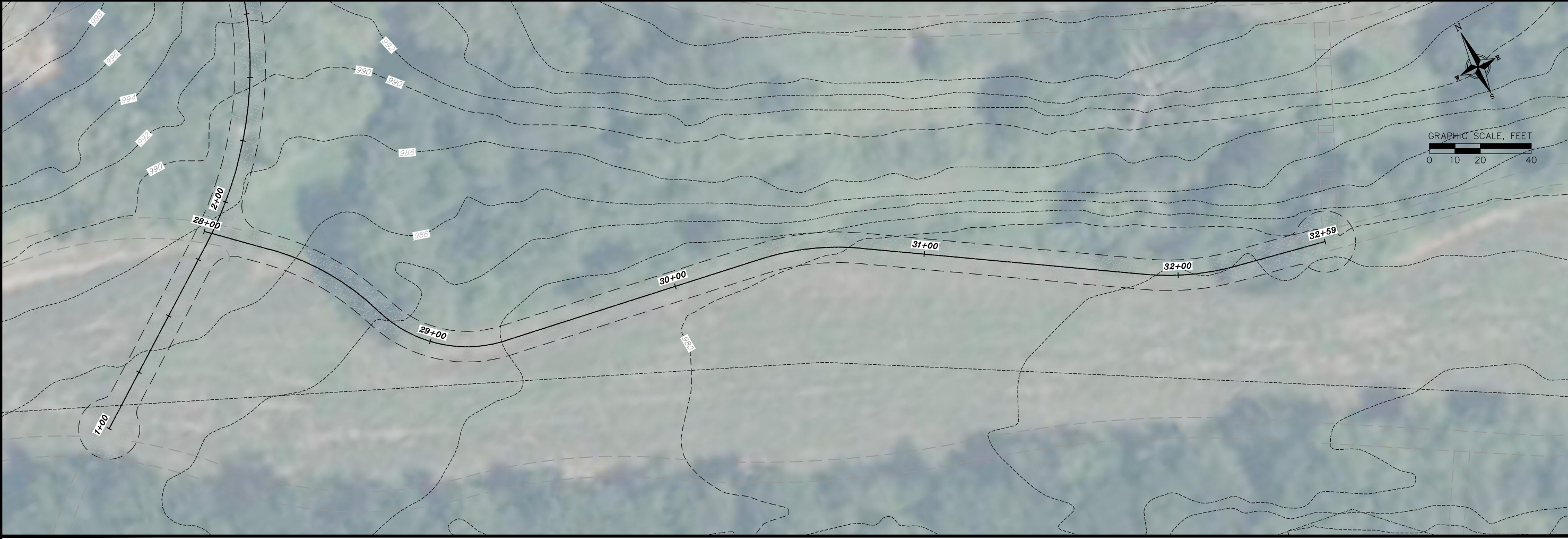

TRAIL SECTION 3 - PLAN AND PROFILE

Community Park Trail
TOWN OF NEW GLARUS
GREEN COUNTY, WISCONSIN

REVISIONS		REVISIONS	
NO.	DATE	NO.	DATE

DATE: 09/05/2024
DRAFTER: DPER
CHECKED: TSGH
PROJECT NO.: 230307

C207



N
S
E
W

GRAPHIC SCALE FEET
0 20 40 80

LEGEND

- PROPOSED ASPHALT
- PROPOSED CONCRETE
- PROPOSED GRAVEL SHOULDER
- PROPOSED RETAINING WALL

SITE PLAN - OPTION A
TOWN GARAGE - HAYES LANE
NEW GLARUS
GREEN COUNTY, WI

REVISIONS		REVISIONS	
NO.	DATE	NO.	DATE

DATE: 2024-09-05

DRAFTER: KZIA

CHECKED: CHECKED

PROJECT NO.: 230356

SHEET: --- OF X

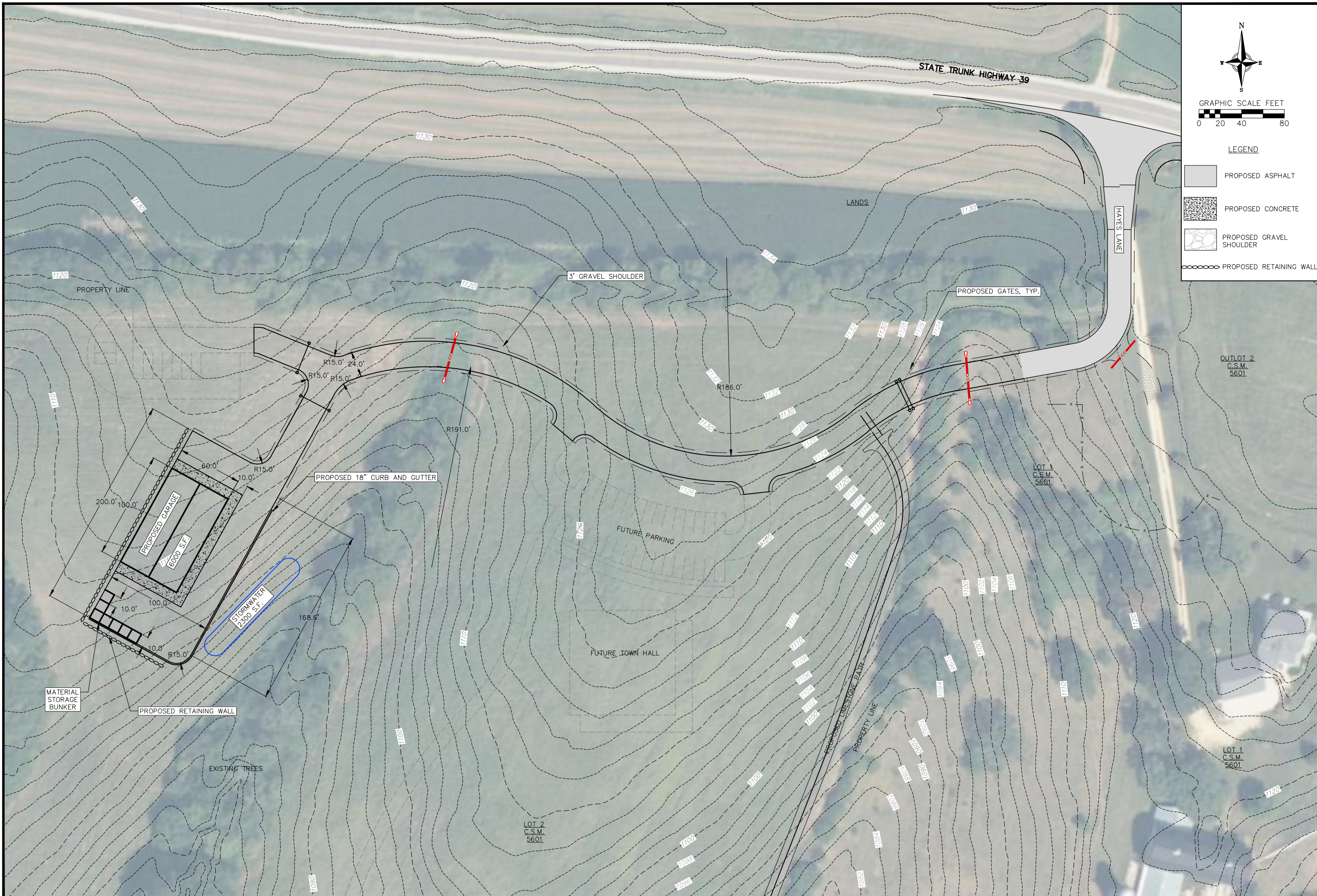

N
 W E
 S

GRAPHIC SCALE FEET
 0 20 40 80

LEGEND

- PROPOSED ASPHALT
- PROPOSED CONCRETE
- PROPOSED GRAVEL SHOULDER
- PROPOSED RETAINING WALL

SITE PLAN - OPTION B
 TOWN GARAGE - HAYES LANE
 NEW GLARUS
 GREEN COUNTY, WI

REVISIONS		REVISIONS	
NO.	DATE	NO.	DATE

DATE
2024-09-05

DRAFTER
KZIA

CHECKED
CHECKED

PROJECT NO.
230356

SHEET
-- OF X

Notice: Some DNR programs allow the value of donated equipment or equipment usage to count as sponsor's match to Department grant funds awarded. If you have an award from one of these grant programs and choose the value of donated equipment or equipment usage to satisfy all or part of sponsor's match requirements, use this form to document donated equipment or equipment usage. Completed form must be submitted with each reimbursement request for which donated equipment or equipment usage is used as sponsor's match to a grant from the Department. Personal information collected on this form will be used for administrative purposes and may be provided to requesters to the extent required by Wisconsin's Open Records law [ss. 19.31-19.39, Wis. Stats.]. Value of donated equipment or equipment usage is typically based on the rate that Wisconsin DOT maintains for Highway Projects. http://dnr.wi.gov/Aid/documents/DOTEquipRates_Standard.pdf?o=n

Grant Recipient's Name	Grant Project Number
------------------------	----------------------

Project Name

Donated Equipment Use Summary

** Federal regulations 43 CFR 12.64(d)(1) related to donated supplies and materials states: If a third party donates the use of equipment or space in a building but retains title, the contribution will be valued at the fair rental rate of the equipment space.*

Leave Blank – DNR Use Only	
Grant Project Title	Grant Number

Date	Name of Operator (Equipment)	Type of Equipment Used	Description of Work Performed	Hours	Rate		Total
					x	=	
					x	=	
					x	=	
					x	=	
					x	=	
					x	=	
					x	=	
					x	=	
					x	=	
					x	=	
					x	=	
					x	=	
Total Donated Equipment Use							

Certification

I hereby certify that the above donated equipment usage have been performed and that this claim is true and correct.

 (Signature of Authorized Representative)

 (Date Signed)

Donated Professional Services Used as Grant Match

Form 8700-350 (R 11/16)

Page 3 of 3

Notice: Professionals donating services to more than one DNR funded grant project during the reimbursement request time period must complete a Section 1.c. below to identified all hours, both paid and donated, contributed to those projects during the time period. It is recommended these reports be completed on a fiscal quarterly basis (Jan-March, April-June, etc.) to support quarterly, semi-annual, or annual reimbursement requests. Staff and Professional Service Providers contributing to multiple projects must submit a signed original of this form along with their invoice(s) or Donated Professional Services worksheet(s).

Section 1.c Force Account / Professional Services Report (Multiple Projects)

Staff/Professional Services Provider:	Hourly (Wages + Benefit Rate)
---------------------------------------	-------------------------------

Professional Title:	Fiscal Quarterly Reporting <input type="radio"/>
	Time Period Reporting <input type="radio"/>

Project/Grant Number	Total # Hours	Services Provided
1.		
2.		
3.		
4.		
5.		
6.		
7.		
8.		
9.		
10.		
11.		
12.		
13.		
14.		
15.		
16.		
17.		
18.		

Certification: This report accurately reflects my professional wage/benefit rate and the number of hours I contributed to Wisconsin DNR grant-funded projects during the time period/fiscal quarter indicated. It identifies all Wis. DNR grant projects I contributed to during this period and is submitted so the value of these hours may be cost-shared or used as match for the grant project(s) indicated. Hours listed are specific to the grant project identified, and are not being billed toward or used as match for any other grant project funded by DNR.

Signature of Professional Service Provider _____ Date _____

Town of New Glarus
Transaction Detail by Account
 January-December, 2024

	Date	Transaction type	Num	Name	Memo/Description	Account full name	Amount	Balance	Account
57620 Parks									
57620-03 Parks Workshops									
	03/13/2024	Bill		Jason Neton	Snacks for Community Input Night and for focus group meetings, 2.27.2024, 3.05.2024, and 3.07.2024	21000 Accounts Payable (A/P)	\$ 123.79	\$ 123.79	57620-03 Parks Workshops
Total for 57620-03 Parks Workshops							\$ 123.79		
57620-05 Parks Printing									
	03/13/2024	Bill	2731	Audio-Visual Center & Print Shop	2,000 printed pages, 1-sided B&W on green stock, to insert in the Buyer's Guide re: Community Input for Master Park Plan	21000 Accounts Payable (A/P)	\$ 75.25	\$ 75.25	57620-05 Parks Printing
	03/13/2024	Bill	135063	Finger Publishing, Inc	1,874 flyers for Park Commission re: Community Input Night	21000 Accounts Payable (A/P)	\$ 149.29	\$ 224.54	57620-05 Parks Printing
Total for 57620-05 Parks Printing							\$ 224.54		
57620-08 Parks Memberships & Subscriptions									
	06/12/2024	Bill		Visa	Intuit QuickBooks online; 6.01.2024	21000 Accounts Payable (A/P)	\$ 200.00	\$ 200.00	57620-08 Parks Memberships & Subscriptions
Total for 57620-08 Parks Memberships & Subscriptions							\$ 200.00		
Total for 57620 Parks with sub-accounts							\$ 548.33		

Accrual Basis Tuesday, August 13, 2024 04:11 PM GMTZ

2024 Parks Budget

Fund	2024 Budget	Actual to Date	Current Balance
Town Park/Town Trail Sinking Fund	\$ 2,137	\$ -	\$ 38,244
Community Partnerships Sinking Fund	\$ -		\$ 7,365
Certificate of Deposit			\$ 20,805
Community Park Site Evaluation			
Trail Development		\$ -	\$ -
Per Diems (6 members X 13 meetings X \$35 = \$2730 + Chair x 13 meetings x \$50 = \$650 Total \$3,380) + Alternate X 13 meetings X \$35 = \$455	\$ 3,835	\$ -	\$ 3,835
Payroll Taxes (\$3,835 x 7.65%)	\$ 293	\$ -	\$ 293
Parks Workshops/Projects	\$ 2,000	\$ 548	\$ 1,452
Honoraria (\$50 x 5)	\$ 250		
Refreshments	\$ 300		
Facility Rental	\$ -		
Advertising	\$ 1,390		
Mileage reimbursements	\$ 60		
Town Hall beautification (mulch)			
Seeding and Restoration of 20% of Community Park	\$ 5,000	\$ -	\$ -
\$ -			
\$ -			
\$ -			
Hoesly Pond	\$ -	\$ -	\$ -
Tell Grounds	\$ -	\$ -	\$ -
TPE Membership, New Glarus Woods	\$ 250	\$ -	\$ 250
Tree Planting at W6599 STH 39	\$ 85	\$ -	\$ -
Recruitment / Holiday Party			
Pool Scholarships		\$ -	
Krafty Kids			
Maintenance/Restoration of BBRC	\$ 1,400	\$ -	\$ 1,400
Burr Oak Blight Abatement	\$ -		
Invasive Species Abatement	\$ -		
Mowing	\$ -		
Entrance, parking, boundaries	\$ -		
Plants & Trees	\$ -		
Totals	\$ 15,000	\$ 548	\$ 14,452
To Date Budget Balance	\$ 14,452		
Less Per Diems	\$ -		
Less Payroll Taxes	\$ -		
Sub total	\$ 14,452		
Spend or Carry Over to 2025	\$ 14,452		



Town of New Glarus

Budget vs. Actuals: 2024 - FY24 P&L

January - December 2024

	TOTAL			
	ACTUAL	BUDGET	OVER BUDGET	% OF BUDGET
Income				
Total Income			\$0.00	0.00%
GROSS PROFIT	\$0.00	\$0.00	\$0.00	0.00%
Expenses				
57620 Parks	548.33	15,000.00	-14,451.67	3.66 %
Total Expenses	\$548.33	\$15,000.00	\$ -14,451.67	3.66 %
NET OPERATING INCOME	\$ -548.33	\$ -15,000.00	\$14,451.67	3.66 %
NET INCOME	\$ -548.33	\$ -15,000.00	\$14,451.67	3.66 %

	January Special	January	Restoration Committee Jan 3, 2024	February	Community Input: Feb 27, 2024	Focus 1: Mar 5, 2024	Focus 2: Mar 7, 2024	March	April	Walka bout	May	June	July	August	September	October	November	December	Total
Harry Pulliam	\$0	\$50	\$0	\$50	\$35	\$35	\$35	\$50	\$50	\$35	\$50	\$50	\$50	\$50					\$540
Chris Narveson	\$35	\$35	\$0	\$0	\$35	\$35	\$0	\$35	\$35	\$35	\$35	\$35	\$35	\$35					\$385
Mark Pernitz	\$35	\$35	\$0	\$35	\$35	\$35	\$35	\$35	\$35	\$35	\$35	\$35	\$35	\$35					\$455
Dana Emmerton	\$35	\$35	\$0	\$35	\$0	\$0	\$0	\$0	n/a	n/a	n/a	n/a	n/a	n/a					\$105
Mona Sue French	\$0	\$0	\$35	\$35	\$35	\$0	\$0	\$35	\$0	\$0	\$35	\$0	\$35	\$35					\$245
Jason Neton	\$35	\$35	\$0	\$35	\$35	\$0	\$35	\$35	\$35	\$0	\$0	\$35	\$35	\$35					\$350
Kelly Ruschman	\$35	\$35	\$35	\$35	\$0	\$0	\$0	\$35	\$35	\$35	\$35	\$0	\$35	\$35					\$350
Rose Pertzborn, alternate	\$0	\$0	\$35	\$35	\$0	\$0	\$0	\$35	\$35	\$0	\$35	\$35	\$0	\$0					\$210
																			\$2,430

Alternate paid only in absence of a regular member

Rose a regular member in April

Clerk Treasurer

Subject: Park Commission CD comes to term
Location: Bank of New Glarus

Start: Tue 11/19/2024 12:00 AM
End: Wed 11/20/2024 12:00 AM
Show Time As: Tentative

Recurrence: (none)

Meeting Status: Not yet responded

Organizer: Clerk Treasurer
Required Attendees: Harry Pulliam; Chris Narveson; Chris Narveson; Deputy Clerk; Deputy Treasurer

Harry,

In order for the invested Park Commission money to be available for the construction of the internal trail, then when the CD comes to term on November 19, 2024, it will need to be swept out into a money market account. This is a reminder so that no one forgets to attend to this. I think there is a week to ten days grace period to make the transfer.

CD 3789 – X3789 ▾

[Details](#) [Documents](#) [Download](#)

Account information

[Print](#)

Balance

Current balance
Interest rate
Term
Maturity date
Months to maturity

\$20,804.78
5.29%
12 months
Nov 20, 2024
2

Interest

Current accrued interest
Pay interest to
Next interest payment (Nov 19, 2024)
Redemption amount
Forfeiture amount
Renewal terms

\$66.34
This account
\$277.40
\$19,770.55
\$1,100.57
Automatically renewable

Transactions

[Print](#)

Search transactions

○ Pending ● Posted

Total debits: -0.00 (0) Total credits: +20,804.78 (4)

Date ▾	Description ◊	Debit ◊	Credit ◊	Balance
● Aug 19, 2024	INTEREST		273.75	20,804.78
● May 19, 2024	INTEREST		261.46	20,531.03
● Feb 20, 2024	INTEREST		269.57	20,269.57
● Nov 20, 2023			20,000.00	20,000.00

Activity *

All transactions ▾

Type *

All ▾

Amount

Example: 40 or 10.00-50.00

* Indicates required field

I think the balance at date of maturity will be \$21,082.18.

Thanks,

John Wright